

MTB51



EAC

ANALYSIS LTD

[www.analysis-ltd.com.gr](http://www.analysis-ltd.com.gr)

# TEMPERATURE SENSOR

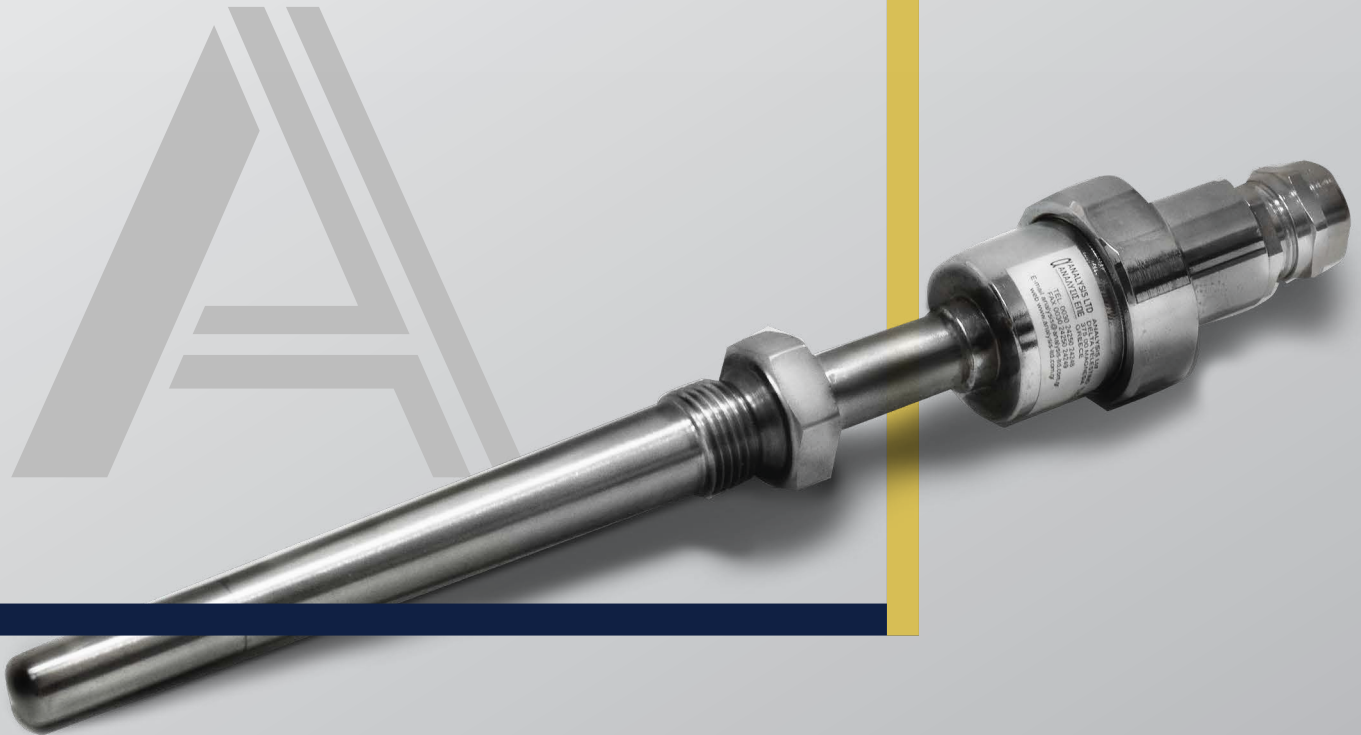

Version: MTB51.1.7-22



### APPLICATIONS

- Marine and Industrial applications
- Cooling water and refrigeration plants
- Oil lubrication and hydraulic oil
- Exhaust gas from diesel engines
- Internal combustion engines, compressors and turbines
- Compressors and turbines

### FEATURES

- Nickel plated head with Cable gland.
- Electrical connection with ceramic block
- Available with exchangeable element. Easy exchange of measuring element even while the application is in operation
- Protection sheath material AISI304 or AISI316
- Protection sheath: tapered solid drilled
- Shock and Vibration Resistance 13.2-100Hz at 0.7g and 25-100Hz at 4.0g

### THERMORESISTANCE (RTD) FEATURES

- Reliable and accurate measurement with Thermoresistance (RTD) element
- Sensing element PT100 Class B DIN EN 60751
- Measuring temperature range -50C to 700C
- Max ambient temperature 75C

### THERMOCOUPLE FEATURES

- Reliable and accurate measurement with thermocouple element
- Measuring temperature range 0C to 800C
- Max ambient temperature 75C





MTB51: Nickel Plated head/ Tapered / Protection sheath Solid Drilled

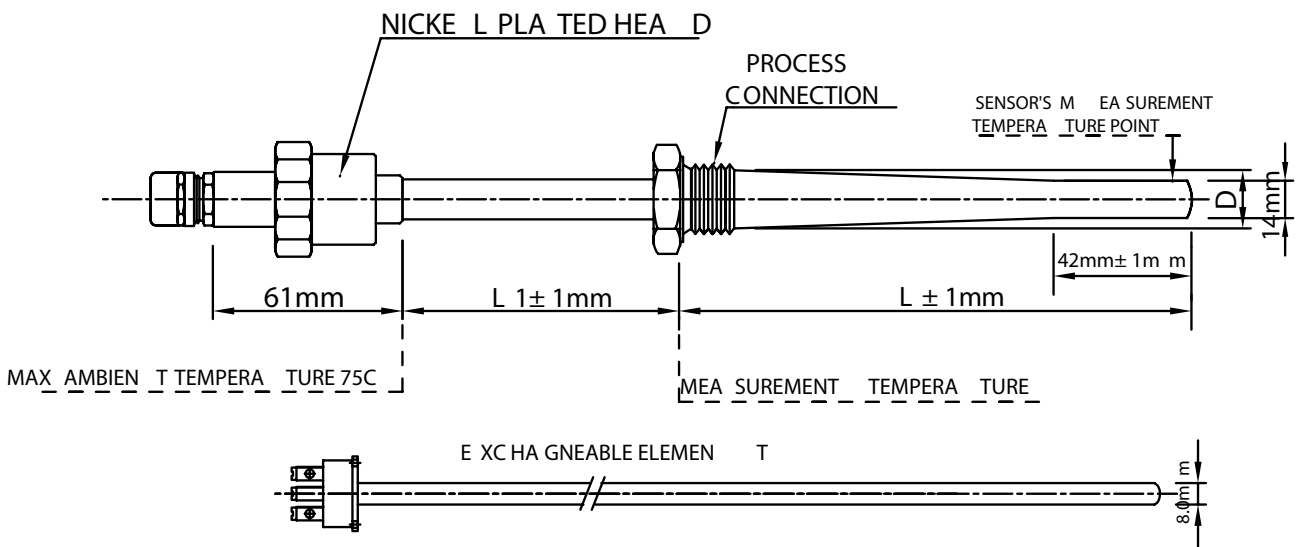



### Thermoresistance (RTD). Color code according to DIN EN 60751

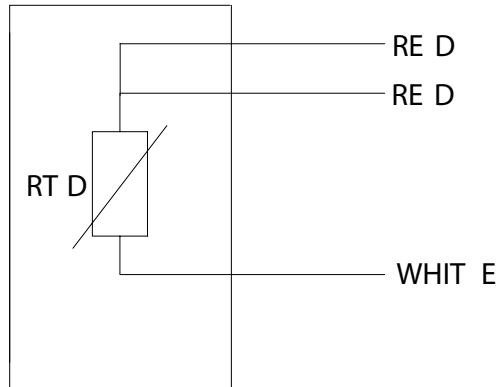
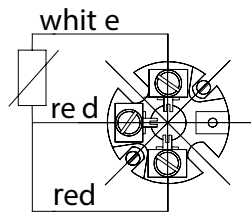

### Thermocouple. Color code according to EN 60584-1

1xK (1xNiCr-NiAl)

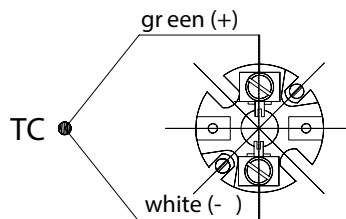

# MTB51

## ORDER CODE



# ANALYSIS LTD

### ORDER CODE FOR MTB51

#### SENSOR ELEMENT: THERMORESISTANCE (RTD) OR THERMOCOUPLE

1xPT100 Class B - 3 Wires DIN EN 60751	2				
1xTYPE K (NiCr-NiAl) Class 1 EN60584-1	1K				
<b>ELEMENT</b>					
EXCHANGEABLE ELEMENT		Y			
NO EXCHANGEABLE ELEMENT		N			
<b>LENGTH L[mm ±1]</b>					
From 50mm to 250mm			---		
OTHER LENGTH L[mm] ON REQUEST			XXX		
<b>LENGTH L1[mm ±1]</b>					
50mm				50	
100mm				100	
OTHER LENGTH L1[mm] ON REQUEST				XXX	
<b>PROTECTION SHEATH MATERIAL</b>					
AISI 304				4	
AISI 316				6	
<b>PROCESS CONNECTION</b>					
G1/2" [D: 18mm]					G12
G3/4" [D: 23mm]					G34
OTHER PROCESS CONNECTION ON REQUEST					XXX

**ORDERING EXAMPLE:** MTB51-2-Y-100-50-4-G34